

ZXT-800

AC/AV MASTER USER MANUAL



APPS DOWNLOAD: [CONEXUM ZXT-800](#)

CONTENTS

| | |
|---|-----------|
| 1. Introduction | 1 |
| 2. Product Overview | 1 |
| 2.1. Description | 1 |
| 2.2. Features | 2 |
| 2.3. Z-Wave Glossary | 3 |
| 3. Get Started | 4 |
| 3.1. Step-1 Apply Power to ZXT-800. | 4 |
| 3.2. Step-2 Include ZXT-800 to a Z-Wave™ Gateway | 5 |
| 3.3. Step-3 Setup Automatic Status Report Associate to Gateway. | 6 |
| 3.4. Step-4 Setup IR code | 6 |
| 3.5. Setup IR Code by ZXT-800 App (AC+AV) | 9 |
| 3.6. IR Code learning | 10 |
| 4. Configuration Master Table | 16 |
| 5. Reset to Factory Default. | 19 |
| 6. Mounting and Placement. | 19 |
| 7. Technical Specifications. | 21 |
| 8. BLE Channels and Frequency. | 22 |
| 9. Warranty. | 23 |
| 10. Regulatory information. | 24 |
| 11. IC Notice | 25 |
| 12. Warnings. | 25 |
| 13. Caution | 25 |

1. Introduction

ZXT-800 is a Z-Wave™ plus compliant Z-Wave™ -to-IR Bridge to control split air conditioner and entertainment devices by receiving Z-Wave™ command and translating to Infrared command. With its comprehensive built-In and cloud-stored IR database (library). ZXT-800 can control different brands and models of infrared devices worldwide.

ZXT-800 is a security enabled Z-Wave™ plus device. A security Enabled Z-Wave™ Plus Controller must be used in order to fully utilize the feature.

ZXT-800 is a Z-Wave™ slave device, it can be up to gateway to setup particular brand with correct IR code. User can setup the IR (AV + AC) code by “Conexum ZXT-800” App through Bluetooth download. iOS and Android App are available in Apps store.

2. Product Overview

2.1 Description

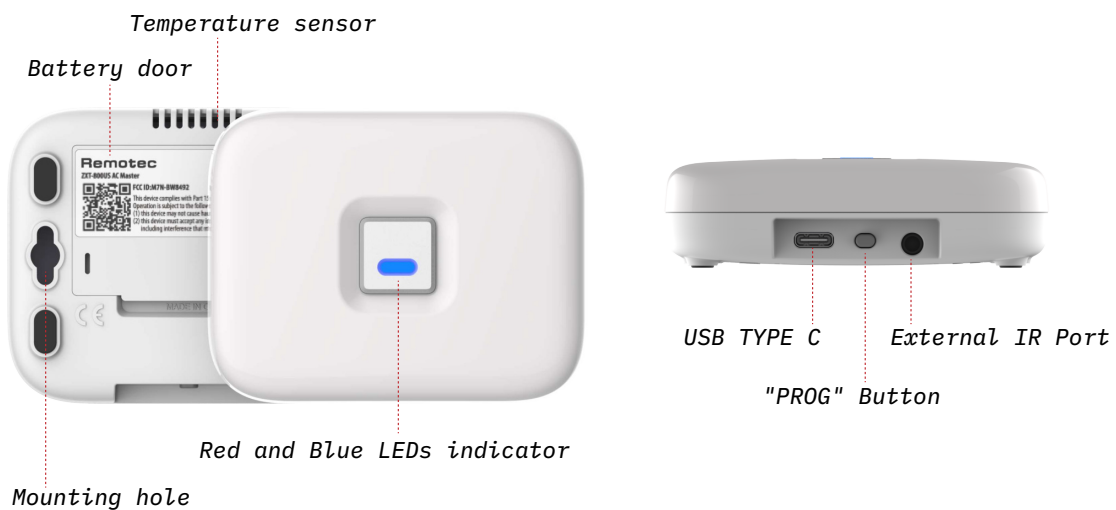

Ⓢ Continued on next page

2.2 Features

- Working as a Z-Wave™ thermostat (AC) and Simple AV device
- Supports Classic Inclusion, NWI and SmartStart
- Built-in AC IR database for worldwide market, direct use it in gateway
- Cloud-base downloadable AC + AV IR library by Smart phone
- Supports Basic, Smart and Learning search in Smart Phone App
- Support IR learning
- Supports AC × 1 and AV × 3 by download
- Support Air-Conditioner Infrared status synchronization (Supported by -0003)
- Built-in temperature and humidity sensor
- Support firmware upgrades via Over-the-air (OTA) by Z-Wave™ and BLE
- Z-Wave™ Plus 2 compliant
- Working on battery (3 × AAA batteries) or USB power
- This product can be operated in any Z-Wave™ network with other Z-Wave™ certified devices from other manufacturers. All mains operated nodes within the network will act as repeaters regardless of vendor to increase reliability of the network.
- SmartStart enabled products can be added to a Z-Wave™ network by scanning the Z-Wave™ QR Code on the product with a controller supporting SmartStart inclusion. No further action is required and the product will be added automatically within 10 minutes of being switched on nearby.

Ⓣ Continued on next page

2.3 Z-Wave Glossary

| | |
|-------------------------------------|--|
| Device or Node | Devices and nodes are all terms to describe an individual Z-Wave™ device. These are all interchangeable when setting up your Z-Wave™ network. |
| Inclusion | Add a Z-Wave™ device to the network. |
| Exclusion | Remove a Z-Wave™ device from the network. |
| Remove | Remove a Z-Wave™ device from the network. |
| Network Wide Inclusion (NWI) | Network Wide Inclusion (NWI) enables both end-user friendly, Plug and Play like Z-Wave™ network installation as well as professional installation scenario where the inclusion process, in terms of time will be reduced significantly. NWI is a feature supported by a new frame type named Explorer which enables the Z-Wave™ protocol to implement Adaptive Source Routing. |
| Z-Wave Network | A collection of Z-Wave™ devices is controlled by primary and secondary controllers operating on the same system. A Z-Wave™ network has its own unique ID code so that controllers not in the network cannot control the system. |
| Indicator Command | The device supports the Indicator Command Class and support the Indicator ID 0x50 (Identify) and Properties ID 0x03, 0x04 and 0x05 |
| FLiRS Mode | FLiRS is abbreviation for “Frequently Listening Routing Slave”. FLiRS mode is targeted for battery operated applications and will enter sleep mode frequently in order to conserve battery consumption. The response to Z-Wave™ command is not as quick as Always Listening Device. Normally there is 1-2 seconds latency. |
| Always-Listening Mode | Always Listening Mode is targeted for AC power operated applications and it can act as a repeater, which will re-transmit the RF signal to ensure that the signal is received by its intended destination by routing the signal around obstacle and radio dead spots. The response to Z-Wave™ command is immediate. |
| Association | Association is used to organize nodes in different groups allowing the device to identify the nodes by a group identifier. The groups can also be copied to other devices. |
| Thermostat mode | Thermostat may support mode: OFF / HEAT / COOL /AUTO/ RESUME(ON)/ FAN ONLY /DRY AIR which depends on AC code. |

3. Get Started

User Guide × 1

ZXT-800 × 1

3.1 Step-1 Apply Power to ZXT-800

- 3 × AAA batteries or USB TYPE C
- ZXT-800 will detect the first applied power source to decide what Z-Wave™ device role it will be in after included into the Z-Wave™ gateway:
 - Battery = sleeping device (FLiRS mode)
 - USB power = always awake device (Always Listening mode)

Please refer to Z-Wave™ Glossary for more information.

- Once the ZXT-800 is included into a Z-Wave™ network, the working mode (sleeping or awake) cannot be changed, unless it is excluded and re-apply the power.
- ZXT-800 can be included and operated in any Z-Wave™ network with other Z-Wave™ certified devices from other manufacturers and/or other applications. All non-battery operating nodes within the network will act as repeaters regardless of Vendor to increase reliability of the network.

Caution

- Use new batteries of the recommended type and size only.
- Never mix used and new batteries together.
- To avoid chemical leaks, remove batteries from the ZXT-800 if you do not intend to use the device for an extended period of time.
- Dispose of used batteries properly; Do not burn or bury them.

3.2 Step-2 Include ZXT-800 to a Z-Wave™ Gateway

There are two methods to include to a Z-Wave™ network,

Classic inclusion

| Step | Procedure / Description | Status Indicator |
|------|---|---|
| 1 | Refer to your primary controller to enter into the Inclusion Mode or Exclusion Mode | - |
| 2 | Once the primary controller is ready to include/exclude the device, press the “PROG” button once. | Purple LED will flash until complete the step of inclusion / exclusion. If success, blue LED will flash twice; if fail, red LED will flash twice. |

SmartStart inclusion

| Step | Procedure / Description | Status Indicator |
|------|---|---|
| 1 | Refer to your primary controller (gateway) instruction then use Smart Phone App to scan ZXT-800 SmartStart QR code, it will include the device into the Z-Wave™ network automatically. User can find out the QR code at device bottom Z-Wave™ DSK area. Make sure your gateway supports SmartStart feature. | Purple LED will flash until complete the step of inclusion / exclusion. If success, blue LED will flash twice; if fail, red LED will flash twice. |

Notes

- *It is recommended to perform the Remove (Exclude) procedure before performing an Add (Include) procedure.*
- *If the Add (Include) process fails, try to Remove (Exclude) from your primary controller (or reset the ZXT-800 to Factory Default), then repeat the above steps.*

Ⓣ Continued on next page

3.3 Step-3 Setup Automatic Status Report Associate to Gateway

Please refer to your primary controller (gateway) instruction for more detail. Normally, User can ignore this step during the setup.

ZXT-800 support 1 association group, Association Group #1 (max. 1 node) is default to associate with the primary controller (Gateway/Hub/Controller) for ZXT-800 status change report, refer to below for report details:

- Current Room Temperature (report in precision of 0.5°C or 1°F), It will be according to Configuration Parameter 30 setting to decide the trigger level.
- Current Battery Level (Only apply in Low Battery Warning happened)
- Device Reset Locally Notification (Only report when the ZXT-800 has been triggered the RESET TO DEFAULT)

3.4 Step-4 Setup IR code

The user interface of setup the IR code varies from different gateways. If gateways have dedicated UI for the IR code setup, please refer to the gateway UI and ignore the below steps.

If your gateway does not have dedicated UI for ZXT-800 IR code setup, but support Z-Wave™ Configuration Command Class. Please refer to below method-A to setup the IR code using the configuration options in your gateway.

Ⓣ *Continued on next page*

There are two methods A) and B) to set up IR code:

A) By Z-Wave™ gateway configuration (Setup AC code with internal library)

| Step | Procedure / Description | Status Indicator |
|------|---|--|
| 1 | Refer to your primary controller user manual, enter Configuration setting. | - |
| 2 | Set up IR code with internal library, Input parameter number: 27, Input parameter value: XXXX (AC code no.); User can scan product QR code (near the Z-Wave™ logo) which will reach to our Code Finder Webpage, it obtains a list of AC codes. Example: AC IR code number: 13; Parameter no.: 27 (Setup IR code); Parameter value size: 2 bytes; Parameter value: 0013 (AC code number); Then activate or save it in gateway. | Purple LED will turn on. If success, blue LED flash ONCE; If fail, red LED will flash TWICE. |
| 3 | Once you finished the IR code setup, please go back to the control page of ZXT-800 on the gateway's Browser or App. Try the function such as (Cool, Temperature Set). If the Air Conditioner does not respond to the command you set on the Gateway (Cool, Heat, Auto, Temperature Set, etc...), repeat step 2 to step 3. Select the next IR code for test from the code list. | Red LED flashing ONCE if device sends out one IR. |

Important Notes

- Above procedures are for AC code configuration only.
- Different brand or model of air conditioner has different function. For example, some air conditioner only support temperature set from 10°C - 30°C, if user set 17°C on gateway, ZXT-800 will not respond it.
- There are more than 1 code for each brand, some does not support Heat, if User selected a code that does not support Heat but original air conditioner supports Heat Function, please continue to try next code until the correct one is selected.
- It is not allowed to set up the IR Code when the battery level below 20%.
- You can record down your Device Code for future reference after setting up the ZXT-800 correctly.
- AC code set: _____

B) By Smart Phone App “Conexum ZXT-800” (Setup AC + AV with cloud library)

User can download “Conexum ZXT-800” App to implement Basic Search for AC and Smart Search for AV then setup the IR code. ZXT-800 supports AC × 1 and AV × 3 devices storage memory. Once your IR code setup completed, user should add ZXT-800 into the Z-Wave™ network then control it directly.

Please make sure Z-Wave™ gateway support AV control interface when you setup AV control. For more detail operation, please refer to below section.

Ⓣ Continued on next page

3.5 Setup IR Code by ZXT-800 App (AC+AV)

1. Please install “Conexum ZXT-800” App, turn on the “Bluetooth” and “GPS”, “WiFi / 4G” on the Smart phone. The App is available in Google Play & Apple App Store.



2. Pair with ZXT-800 by Smart Phone BLE

- Open the App and follow the Smart phone setup UI.
- Press “Add extender”.
- Triple click on the PROG button within 1.0s to pair with Smart Phone, blue LED will keep flashing.
- In Smart Phone, please select “Conexum unit” that you want to pair it.
- Once BLE pairing completed, blue LED will turn off.

3. IR code set up

- For AC setup, please type-in or select your brand then follow the Basic Search to test it one by one.
- For AV setup, please select your device type (TV, CBL, B-Ray, Soundbar…), brand then follow the Smart Search steps to test it.
- Once you have successfully found an IR Code that matches your device, tap to confirm the code and download it into the ZXT-800.

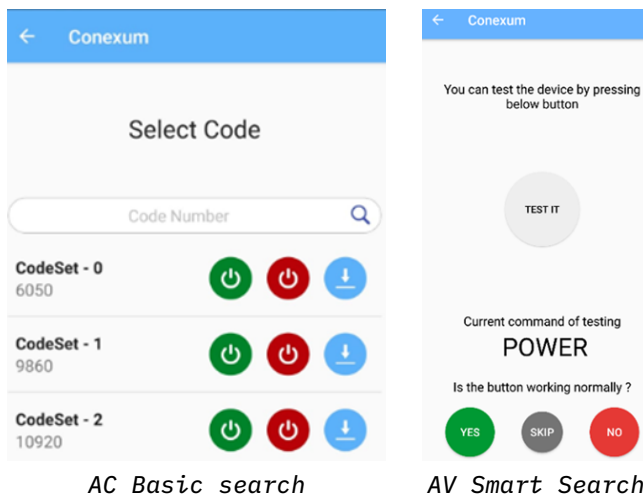

4. After IR code setup completed, please refer to Z-Wave™ inclusion and add ZXT-800 into the Z-Wave™ network, then go to your Z-Wave™ control panel for device control directly.

3.6 IR Code learning

In case the IR code can't support full keys controls, user can use the IR learning function to capture the IR data from original remote controller, please follow below steps.

AC IR Code Learning

Please refer to “Configuration Master Table” for all configuration settings.

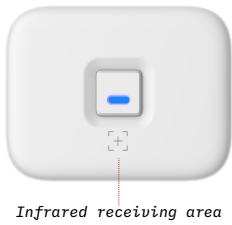
| Step | Procedure / Description | Status Indicator |
|------|--|--|
| 1 | Refer to your primary controller user manual, enter Configuration setting. | - |
| 2 | To learn AC IR code, look up AC Learning Mapping Table for learning and decide which IR setting you wants to learn, <i>example</i> :Parameter number: 25 (Learn AC IR code) Parameter value size: 1 byte Parameter value: 5 (Cool mode, 20°C) Then activate or save it in gateway. | Then Red LED turns ON for indicating the IR Code Learning |
| 3 | <p>Learning location:</p>  <p>Adjust your original AC remote to Cool mode 21°C, aim your original AC remote to ZXT-800 according to above position within 1-3cm. Press and release temperature down button to adjust to 20°C, ZXT-800 will learn the IR code automatically. If the learning is failed or need to learn next IR code, repeat step 2 to step 3.</p> | Successful: Blue LED flashes TWICE; Unsuccessful: Red LED flashes TWICE |
| 4 | Once you finished the IR Code Learning, please go to Configuration setting page on the Gateway. Parameter number: 27 (Set IR code) Parameter value size: 2 bytes Parameter value: 0000 (AC learning location) Then activate or save it in gateway. ZXT-800 will set the code number to “0000” which is AC learning code location. | - |

Ⓣ Continued on next page

TIPS

1. User need at least Learn the OFF (Parameter Value 0), and one Temperature Mode (Parameter Value 2 ~ 28) to complete the usage model.
2. Keep away from Incandescent Light or Direct Sunlight during learning.
3. Make sure IR Transmitter of your Original Remote align with learning diode of ZXT-800, you may also slight adjust closer or further away the distance of two devices. Some of Remotes the IR transmitter in hidden behind lens and may not installed center of remote.
4. Make sure the power is good on both devices, especially the Original remote. Use Fresh Batteries in both devices recommended. ZXT-800 will not implement the learning process if the battery level below 20%.

Ⓣ Continued on next page

| Parameter-Value (Storage Location) | Thermostat Command & IR Setting | |
|---------------------------------------|---------------------------------|----------------------------|
| | Storage in Celsius Unit | Storage in Fahrenheit Unit |
| 0 | OFF | OFF |
| 1 | ON (RESUME) | ON (RESUME) |
| 2 | 17°C Cool | 63°F Cool |
| 3 | 18°C Cool | 64°F Cool |
| 4 | 19°C Cool | 66°F (67°F Cool) |
| 5 | 20°C Cool | 68°F (69°F Cool) |
| 6 | 21°C Cool | 70°F (71°F Cool) |
| 7 | 22°C Cool | 72°F (73°F Cool) |
| 8 | 23°C Cool | 74°F (75°F Cool) |
| 9 | 24°C Cool | 76°F Cool |
| 10 | 25°C Cool | 77°F (78°F Cool) |
| 11 | 26°C Cool | 79°F (80°F Cool) |
| 12 | 27°C Cool | 81°F (82°F Cool) |
| 13 | 28°C Cool | 83°F (84°F Cool) |
| 14 | 29°C Cool | 85°F Cool |
| 15 | 30°C Cool | 86°F Cool |
| 16 | 17°C Heat | 63°F Heat |
| 17 | 18°C Heat | 64°F Heat |
| 18 | 19°C Heat | 66°F (67°F Heat) |
| 19 | 20°C Heat | 68°F (69°F Heat) |
| 20 | 21°C Heat | 70°F (71°F Heat) |
| 21 | 22°C Heat | 72°F (73°F Heat) |
| 22 | 23°C Heat | 74°F (75°F Heat) |
| 23 | 24°C Heat | 76°F Heat |
| 24 | 25°C Heat | 77°F (78°F Heat) |
| 25 | 26°C Heat | 79°F (78°F Heat) |
| 26 | 27°C Heat | 81°F (82°F Heat) |
| 27 | 28°C Heat | 83°F (84°F Heat) |
| 28 | 29°C Heat | 85°F Heat |
| 29 | 30°C Heat | 86°F Heat |
| 30 | Dry Mode | Dry Mode |
| 31 | Auto Mode | Auto Mode |
| 32 | Fan Mode | Fan Mode |

Table 1: AC IR Learning Mapping Table (Parameter number 25)

Mapping Information

1. BASIC Set Value 0x00 will map to Thermostat mode OFF 0x00
2. BASIC Set Value 0xFF will map to Thermostat mode Resume 0x05
3. Energy Saving Mode will map to Thermostat mode OFF

AV IR Code Learning

Please refer to “Configuration Master Table” for all configuration settings.

| Step | Procedure / Description | Status Indicator |
|-------------|--|---|
| 1 | Refer to your primary controller user manual, enter Configuration setting. | - |
| 2 | Select AV endpoint (learning location), example: Parameter number: 38 (Select AV endpoint); Parameter value size: 1 byte; Parameter value: 2 (AV1); Then activate or save it in gateway. | - |
| 3 | To learn AV IR code, look up AV Learning Mapping Table for learning and decide which IR setting you wants to learn, example: Parameter number: 26 (Learn AV IR code); Parameter value size: 1 byte; Parameter value: 11 (VOL+); Then activate or save it in gateway. | Then Red led turns ON for indicating the IR Code Learning. |
| 4 | <p>Learning location:</p>  <p>Aim your original AV remote to ZXT-800 according to above position within 1-3cm. Press and hold the “VOL+” button until blue LED flashes twice. ZXT-800 will learn the IR code automatically. If the learning is failed or need to learn next IR code, repeat step 2 to step 4.</p> | <p>Successful: Blue LED flashes TWICE; Unsuccessful: Red LED flashes TWICE</p> |

Ⓣ Continued on next page

| Parameter-Value (Storage Location) | Simple AV Command & IR Setting | |
|------------------------------------|--------------------------------|-------------------|
| | Function | Z-Wave™ AV key ID |
| 0 | Power | 0x0027 |
| 1 | Input | 0x0026 |
| 2 | Menu | 0x001D |
| 3 | Smart | 0x0185 |
| 4 | Guide | 0x001C |
| 5 | Back | 0x004B |
| 6 | Up | 0x001E |
| 7 | Down | 0x001F |
| 8 | OK | 0x0024 |
| 9 | Left | 0x0020 |
| 10 | Right | 0x0021 |
| 11 | VOL+ | 0x0003 |
| 12 | VOL- | 0x0002 |
| 13 | Mute | 0x0001 |
| 14 | Home | 0x00AF |
| 15 | CH+ | 0x0004 |
| 16 | CH- | 0x0005 |
| 17 | Skip- | 0x011C |
| 18 | Stop | 0x0014 |
| 19 | Skip+ | 0x011B |
| 20 | Play | 0x0013 |
| 21 | Pause | 0x0015 |
| 22 | Rewind | 0x0017 |
| 23 | Record | 0x0019 |
| 24 | Fast Forward | 0x0016 |
| 25 | Red | 0x009D |
| 26 | Green | 0x009B |
| 27 | Yellow | 0x009F |
| 28 | Blue | 0x009A |

Ⓣ Continued on next page

| Parameter-Value (Storage Location) | Simple AV Command & IR Setting | |
|------------------------------------|--------------------------------|-------------------|
| | Function | Z-Wave™ AV key ID |
| 29 | 0 | 0x0006 |
| 30 | 1 | 0x0007 |
| 31 | 2 | 0x0008 |
| 32 | 3 | 0x0009 |
| 33 | 4 | 0x000A |
| 34 | 5 | 0x000B |
| 35 | 6 | 0x000C |
| 36 | 7 | 0x000D |
| 37 | 8 | 0x000E |
| 38 | 9 | 0x000F |
| 39 | Info | 0x0011 |
| 40 | Text | 0x013F |

Table 2: AV IR Learning Mapping Table (Parameter number 26)

Air-Conditioner Infrared status synchronization (Supported by -0003)

ZXT-800 support Air-Conditioner IR status synchronization, it will report the AC status to Z-Wave™ or Bluetooth gateway once received the IR command from the AC remote controller. ZXT-800 should be installed at or near to the air-conditioner, the IR coverage distance is up to 5 meters and depend on the IR code pattern. Make sure ZXT-800 is connected to USB power as it will not going to sleep mode when enabled this AC status sync. function. It is required to download the AC code by Smartphone App or Bluetooth Gateway. Otherwise, it is not allowed to enable this function. Please refer to configuration master table parameter number 62 to enable AC status sync.

Notes

- AC status sync. function will not be supported if set code by internal AC database.
- Please check your original AC remote controller, AC status sync. can support AC remotes come with temperature display only.
- The AC learning will not be supported once enabled AC status sync.
- Suggest operating at “Always Listening Mode” if enabled AC status sync. and powered by USB as it can provide fast response to gateway.

4. Configuration Master Table

Please using the correct data format, if the Gateway support decimal numbering format, please use decimal value accordingly. If the Gateway support hexadecimal numbering format, please use hex value accordingly.

| Parameter Name/Description | Parameter Number | Parameter Value | Size (Byte) |
|---|------------------|---|-------------|
| Learn AC IR code | 25 (0x19) | Storage location 0 32 for AC IR code learning (refer to AC learning mapping table) | 1 |
| Learn AV IR code | 26 (0x1A) | Storage location 0 40 for AV IR code learning (refer to AV learning mapping table) | 1 |
| Set IR code from built-in AC library | 27 (0x1B) | Refer to AC code list find from code finder page by code list QR code AC Learning code number = 0000(0x0000) | 2 |
| External IR Emitter power level | 28 (0x1C) | 0(0x00) - normal power mode 255(0xFF) - high power mode (default) | 1 |
| Set Auto Report Condition, Trigger by Room Temperature change | 30 (0x1E) | 0(0x00) = Disable AUTO report function (default) It can extend the battery life. Auto report if room temperature is different from last report 1(0x01) = 1°F (0.5°C) 2(0x02) = 2°F (1°C) 3(0x03) = 3°F (1.5°C) 4(0x04) = 4°F (2°C) 5(0x05) = 5°F (2.5°C) 6(0x06) = 6°F (3°C) 7(0x07) = 7°F (3.5°C) 8(0x08) = 8°F (4°C) | 1 |
| Set Built-in IR Emitter Control | 32 (0x20) | It is allowed to disable internal IR emitter if use external IR emitter jack, it can extend the battery life. 0(0x00) = Disable 255(0xFF) = Enable (default) | 1 |

| | | | |
|---|-----------|--|---|
| Control Air conditioner "Swing" function | 33 (0x21) | 0(0x00) = Swing OFF 1(0x01) = Swing Auto (default) | 1 |
| Temperature and Humidity Auto Report | 34 (0x22) | Set Auto Report Condition by Time Interval 0(0x00) = Disable AUTO report (default) 1(0x01) = 15 mins 2(0x02) = 30 mins 3(0x03) = 1 Hr 4(0x04) = 2 Hrs 5(0x05) = 3 Hrs 6(0x06) = 4 Hrs 7(0x07) = 8 Hrs | 1 |
| Calibrate temperature reading | 37 (0x25) | Temperature offset value 0(0x00) = 0°C (default) 1(0x01) = 0.5°C 2(0x02) = 1°C 3(0x03) = 1.5°C 4(0x04) = 2°C 5(0x05) = 2.5°C 6(0x06) = 3°C 7(0x07) = 3.5°C 8(0x08) = 4°C 9(0x09) = 4.5°C 10(0x0A) = 5°C 255(0xFF) = -0.5°C 254(0xFE) = -1°C 253(0xFD) = -1.5°C 252(0xFC) = -2°C 251(0xFB) = -2.5°C 250(0xFA) = -3°C 249(0xF9) = -3.5°C 248(0xF8) = -4°C 247(0xF7) = -4.5°C 246(0xF6) = -5°C | 1 |

| | | | |
|------------------------------|------------|---|---|
| Select AV endpoint | 38 (0x26) | 2(0x02) = end point 2 (AV1) default 3(0x03) = end point 3 (AV2) 4(0x04) = end point 4 (AV3) | 1 |
| Calibrate humidity reading | 53 (0x35) | 0(0x00) = 0% (default) 1(0x01) = 1% to 30(0x1E) = 30% 255(0xFF) = -1% to 226(0xE2) = -30% | 1 |
| Trigger BLE advertising | 60 (0x3C) | 0(0x00) = Disable BLE advertising (default) 255(0xFF) = Enable BLE advertising, please also set Parameter 61 below. (If the ZXT-800 is installed at ceiling location, user can trigger BLE advertisement through the Z-Wave™ Configuration without click the PROG button.) | 1 |
| BLE advertising option | 61 (0x3D) | 0(0x00) = ZXT-800 advertises for 10 minutes then stop (default) 1(0x01) = ZXT-800 keep advertising, it is suitable for USB supply power | 1 |
| Air-Conditioner status sync. | 62 (0x3E) | 0(0x00) = Disable AC status sync. (default) 255(0xFF) = Enable AC status sync. It is required to download the AC code by Smartphone App or Bluetooth Gateway. Otherwise, it is not allowed to enable this function. | 1 |
| Device reset to default | 160 (0xA0) | 255(0xFF): device reset to default | 1 |
| Send learnt AC IR key | 165(0xA5) | 0(0x00) default 0-32(0x00 - 0x20) =Storage Location (Refer to AC learning mapping table) | 1 |
| Send learnt AV IR key | 166(0xA6) | 0(0x00) default 0-40(0x00 - 0x28) = Storage Location (Refer to AV learning mapping table) Use Parameter Number 38(0x26) to select AV device Endpoint | 1 |

5. Reset to Factory Default

NOTE : Please use this procedure only when the network primary controller is missing or inoperable.

- Press and Hold “PROG” button for 6 seconds on ZXT-800, the Purple indicator will light up. DO NOT release the “PROG” button until Blue indicator flashes TWICE.
- Device will be excluded from network, All Configuration Parameters will be re-stored to factory default. All downloaded IR data and learned data will be cleared.
- ZXT-800 will send Device Reset Locally Notification to gateway.
- ZXT-800 will not implement the Reset to Factory Default when the battery level below 20%.

6. Mounting and Placement

- The ZXT-800 should be mounted on an inner wall about 5ft (1.5m) above the floor where it is readily affected by changes of the general room temperature with freely circulating air.
- Before mounting, check the material and structure of the mounting location. If the location does not have the proper material or structure, the ZXT-800 can fall and cause an injury.
- Avoid mounting above or near hot surfaces or equipment (e.g. TV, Heater, Refrigerator). Avoid mounting where it will be exposed to direct sunshine, drafts, or in a laundry room or other enclosed space.
- Better to mount your device where it has no any obstacle or blocked object between the device and your AC Appliance.

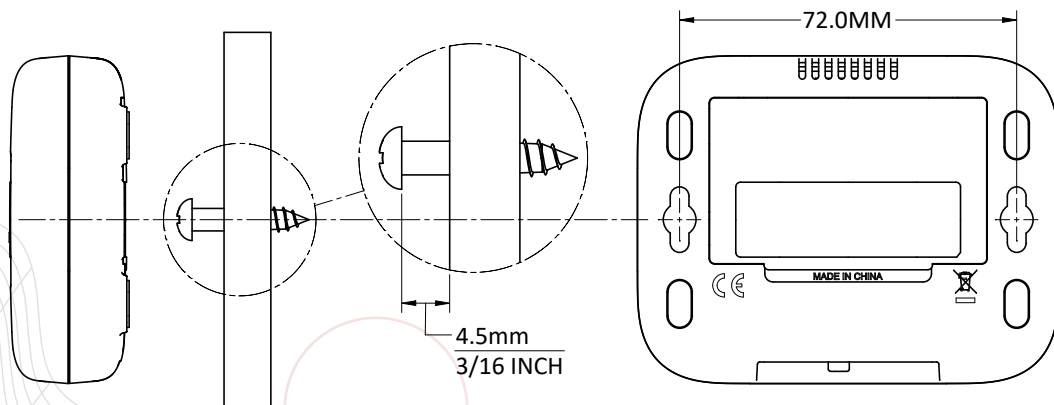

- Position ZXT-800 on wall, level and mark hole positions with pencil.
- Drill holes at marked positions, then tap in supplied wall anchors.
- Insert and tighten mounting screws as above figure.

Ⓣ Continued on next page

7. Technical Specifications

| | |
|--------------------------------------|---|
| Model number | BW8493US (ZXT-800US) BW8493EU (ZXT-800EU) BW8493AU (ZXT-800AU) BW8493JP (ZXT-800JP) BW8493KR (ZXT-800KR) BW8493IN (ZXT-800IN) BW8493IL (ZXT-800IL) BW8493CN (ZXT-800CN) BW8493HK (ZXT-800HK) |
| RF Frequency | 908.4MHz (ZXT-800US) 868.4MHz (ZXT-800EU) 921.4MHz (ZXT-800AU) 922-926MHz (ZXT-800JP) 919-923MHz (ZXT-800KR) 865.2MHz (ZXT-800IN) 916.0MHz (ZXT-800IL) 868.4MHz (ZXT-800CN) 919.80MHz (ZXT-800HK) |
| RF Operating Distance | Up to 500ft / 150m outdoor line of sight, in unobstructed environment |
| Temperature Measurement | Measurable range: 0 °C ~40°C / 32°F ~104°F Report resolution: 0.5°C / 1°F |
| Operating Ambient Temperature | 0°C ~ 40°C, non-condensing |
| Storage Temperature | -10°C ~ 50°C |
| Powered Source | USB Power DC 5V 1A or Alkaline Batteries AAA × 3pcs |
| Size | 90mm × 70mm × 25.5mm |
| Weight | 70g (exclude battery) |

8. BLE Channels and Frequency

| RF FREQUENCY MHZ | CHANNEL TYPE | DATA CHANNEL INDEX | ADVERTISING CHANNEL INDEX |
|------------------|---------------------|--------------------|---------------------------|
| 2402 | Advertising channel | | 37 |
| 2404 | Data channel | 0 | |
| 2406 | Data channel | 1 | |
| 2408 | Data channel | 2 | |
| 2410 | Data channel | 3 | |
| 2412 | Data channel | 4 | |
| 2414 | Data channel | 5 | |
| 2416 | Data channel | 6 | |
| 2418 | Data channel | 7 | |
| 2420 | Data channel | 8 | |
| 2422 | Data channel | 9 | |
| 2424 | Data channel | 10 | |
| 2426 | Advertising channel | | 38 |
| 2428 | Data channel | 11 | |
| 2430 | Data channel | 12 | |
| 2432 | Data channel | 13 | |
| 2434 | Data channel | 14 | |
| 2436 | Data channel | 15 | |
| 2438 | Data channel | 16 | |
| 2440 | Data channel | 17 | |
| 2442 | Data channel | 18 | |
| 2444 | Data channel | 19 | |
| 2446 | Data channel | 20 | |
| 2448 | Data channel | 21 | |
| 2450 | Data channel | 22 | |
| 2452 | Data channel | 23 | |
| 2454 | Data channel | 24 | |
| 2456 | Data channel | 25 | |
| 2458 | Data channel | 26 | |
| 2460 | Data channel | 27 | |

| RF FREQUENCY MHZ | CHANNEL TYPE | DATA CHANNEL INDEX | ADVERTISING CHANNEL INDEX |
|------------------|---------------------|--------------------|---------------------------|
| 2462 | Data channel | 28 | |
| 2464 | Data channel | 29 | |
| 2466 | Data channel | 30 | |
| 2468 | Data channel | 31 | |
| 2470 | Data channel | 32 | |
| 2472 | Data channel | 33 | |
| 2474 | Data channel | 34 | |
| 2476 | Data channel | 35 | |
| 2478 | Data channel | 36 | |
| 2480 | Advertising channel | | 39 |

9. Warranty

ONE-YEAR LIMITED WARRANTY: Remotec warrants this product to be free from defects in materials and workmanship under normal use and service for a period of one year from the original date of purchase from the distributors or dealer.

REMOTEC shall not be liable for: Damages caused by defective devices for indirect, incidental, special, consequential or punitive damages, including, inter alia, loss of profits, savings, data, loss of benefits, claims by third parties and any property damage or personal injuries arising from or related to the use of the device. Service trips to provide instruction on product use.

Shipping costs for replacement products.

This warranty is limited to the repair or replacement of this product only, if the purchase date cannot be substantiated, the warranty period will begin on the date of manufacture as indicated on this product. All warranty claims must be made to Remotec appointed distributors or dealers during the applicable warranty period. This warranty gives you specific legal right and you may also have other rights which vary in each country.

Website : <https://www.remotec.com.hk>

10. Regulatory information

FCC ID : M7N-BW8493

FCC Compliance Statement

This device complies with Part 15 of the FCC rules. Operation is subject to the following two conditions:

- This device may not cause harmful interference, and
- This device must accept any interference received, including interference that may cause undesired operation.

This equipment has been tested and found to comply with the limits for a Class B digital device, pursuant to Part 15 of the FCC Rules. These limits are designed to provide reasonable protection against harmful interference in a residential installation. This equipment generates, uses and can radiate radio frequency energy and, if not installed and used in accordance with the instructions, may cause harmful interference to radio communications. However, there is no guarantee that interference will not occur in a particular installation. If this equipment does cause harmful interference to radio or television reception, which can be determined by turning the equipment off and on, the user is encouraged to try to correct the interference by one or more of the following measures:

- Reorient or relocate the receiving antenna.
- Increase the separation between the equipment and receiver.
- Connect the equipment into an outlet on a circuit different from that to which the receiver is connected.
- Consult the dealer or an experienced radio/TV technician for help.

Notice: Changes or modifications to this unit not expressly approved by the party responsible for compliance could void the user authority to operate the equipment.

To maintain compliance with FCC's RF Exposure guidelines, This equipment should be installed and operated with minimum 20cm distance between the radiator and your body: Use only the supplied antenna.

11. IC Notice

This device complies with Industry Canada licence-exempt RSS standard(s). Operation is subject to the following two conditions:

- This device may not cause interference, and
- This device must accept any interference, including interference that may cause undesired operation of the device.

Le présent appareil est conforme aux CNR d'Industrie Canada applicables aux appareils radio exempts de licence. L'exploitation est autorisée aux deux conditions suivantes:

- l'appareil ne doit pas produire de brouillage, et
- l'utilisateur de l'appareil doit accepter tout brouillage radioélectrique subi, même si le brouillage est susceptible d'en compromettre le fonctionnement.

12. Warnings

- Do not modify the unit in any way.
- Risk of fire; Risk of burns.
- Risk of electrical shock.
- Don't dispose of electrical appliances as unsorted municipal waste, use separate collection facilities. Contact your local government for information regarding the collection systems available.
- There is no user serviceable parts in this unit.

13. Caution

- Risk of explosion if battery is replaced by an incorrect type.
- When replacing the battery use a flathead screwdriver to pry open the battery door.
- Dispose of used batteries according to the instructions.